

4 3 2 1

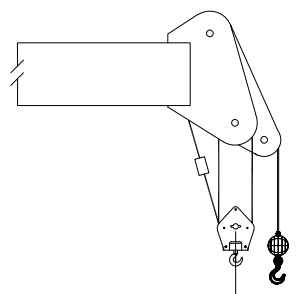
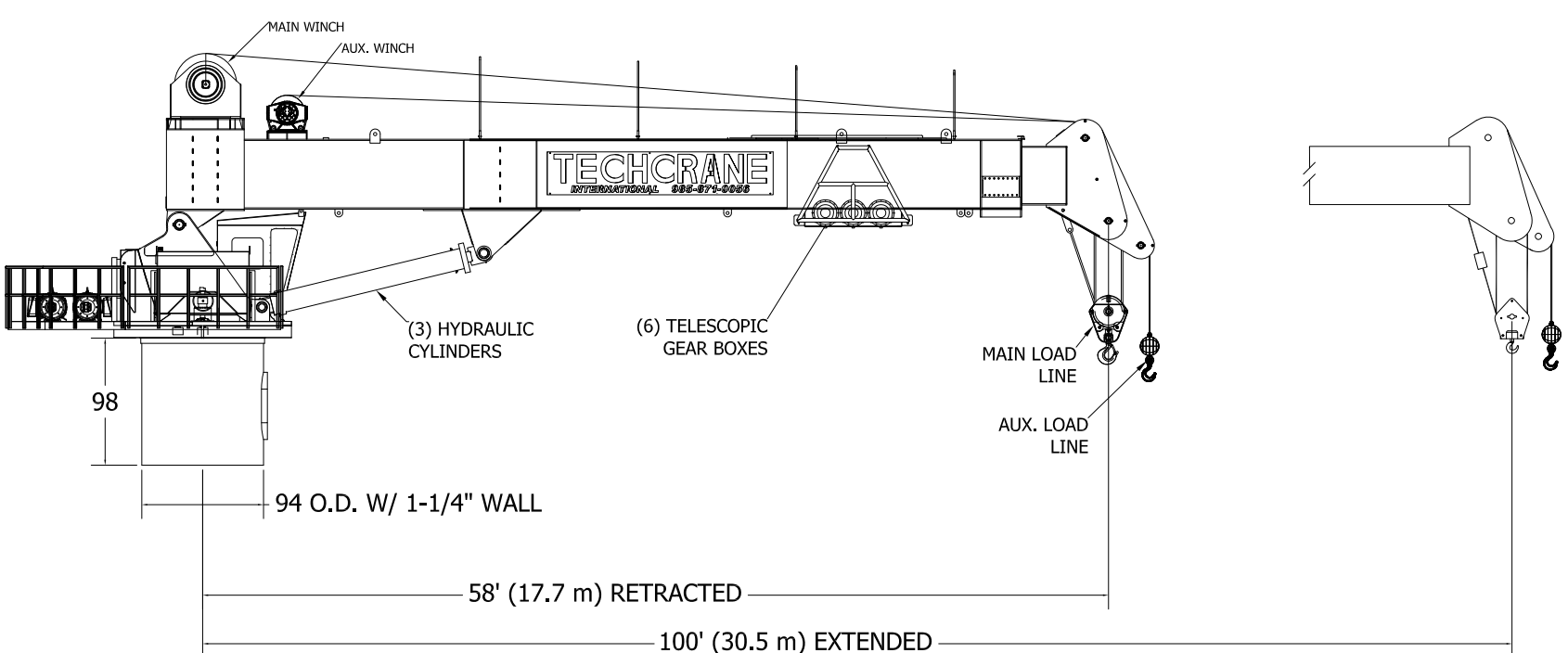
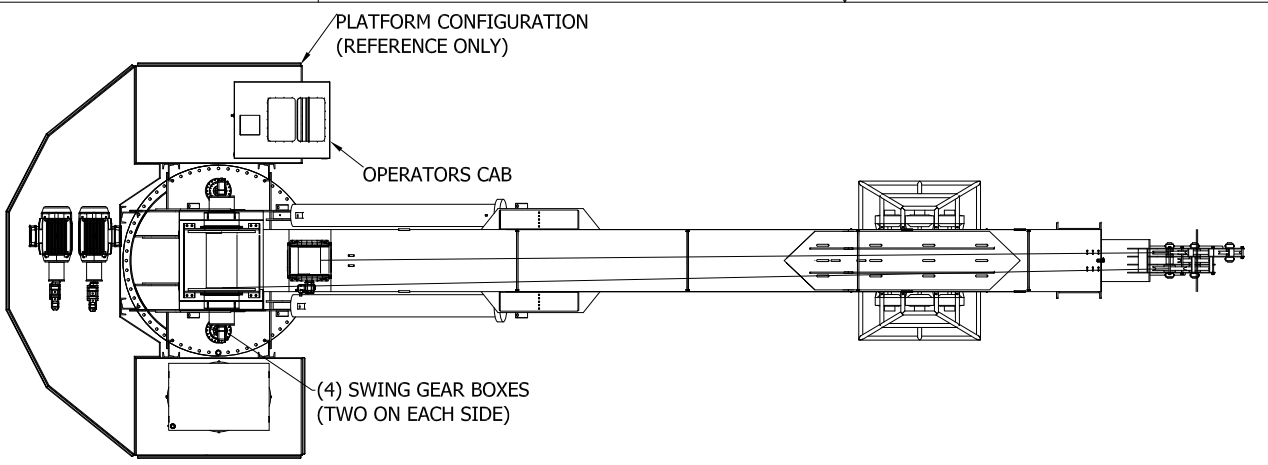

INFORMATION CONTAINED HEREON IS
CONFIDENTIAL AND TRADE SECRET
DO NOT DISCLOSE, USE OR REPRODUCE
WITHOUT PRIOR WRITTEN APPROVAL
FROM TECHCRANE INTERNATIONAL LLC.

DESIGNED BY:
F. Shad

DRAWN BY:
L. BAYLIS

WEIGHT:
N/A

APPROVED BY:

FILE NAME:

MATERIAL NOTES:
1. BURN PER DIMENSIONS SHOWN.
2. PLATE FLATNESS AFTER BURNING TO BE
WITHIN ASTM SPECIFICATIONS.
3. REFER TO API SPEC 2C LATEST EDITION.
4. WHERE APPLICABLE - ROLL FORM PER
DIMENSIONS SHOWN.
5. WHERE APPLICABLE - TACK WELD AS
REQUIRED TO SECURE ROLLED CAN.

DESIGN STATE:

MATERIAL:
N/A

TECHCRANE INTERNATIONAL, LLC.
17639 HARD HAT DRIVE COVINGTON, LA, 70435 U.S.A.
PHONE (985) 871-0056 FAX (985) 871-0065

T200-58-100 GENERAL ARRANGEMENT

DATE:
8/31/2017

REVISION NO.:
2.0

SHEET 1 OF 1

PART/DWG. NO.:
Preliminary G.A

4 3 2 1